



Installation Instructions:

(Part # SB76881)

2007-2010 Jeep JK 2Door

XRC Rear Armor Corner Guard Kit

NOTE: Carefully read entire instructions thoroughly before attempting to install this part.

<u>Parts Included:</u>	<u>Qty</u>	<u>Parts Included:</u>	<u>Qty</u>
93-7267 Rear Armor Fender: Drvr	1	90-6808 Hardware Pack: Nutcert	1
93-7277 Rear Armor Fender: Pass	1	3/8" Nutcert	20
93-7055 Fender Lip Guard: Drvr	1	90-6774 Hardware Pack: Nutcert Installation	1
93-7056 Fender Lip Guard: Pass	1	96-5951 Nutcert Tool	1
90-4324 Inner Fender Liner: Drvr	1	3/8" Star Washer	1
90-4325 Inner Fender Liner: Pass	1	3/8" X 2" Socket Head Bolt	1
93-7054 Liner Tab	4	3/8" Gr. 8 Flat Washer	1
90-6807 Hardware Pack: Fender	1	3/8" Gr. 8 Nut: Un-plated	1
3/8" X 1" SS Button Head Bolt	47	90-6781 Hardware Pack: Fender Weather Stripping	2
3/8" Flat Washer	58	90-4330 Fender Weather Stripping	1
3/8" Nylock Nut	40	90-6809 Hardware Pack:	1
3/8"-16 X 1" Hex Bolt Gr. 5	8	90-4345 Double Sided Tape	1
90-6777 Hardware Pack: Inner Fender Liner	1	90-7286 Stainless Vent Backing Plate: Drvr	1
Plastic Retainers	14	90-7287 Stainless Vent Backing Plate: Pass	1

IMPORTANT!: In order to install these fenders you will have to drill holes in the body.

INSTALLATION:

Step 1: Working on one side of the vehicle at a time, unbolt and remove the steps and/or sliders from the vehicle. Save hardware for reinstallation.

Step 2: Remove the fender flairs and inner fenders from the vehicle.

Step 3: Remove the license plate box from the vehicle.

Step 4: Test fit the license plate template on the vehicle. Be sure the mounting holes and the tailgate line up with the template. Due to factory manufacturing variations, the template may need to be adjusted.

Step 5: Unbolt and remove the tail lights from the vehicle. Save the hardware for reinstallation.

Step 6: Remove the rear bumper from the vehicle if it appears that it will interfere with the installation of the rear fender armor. Save the hardware for reinstallation.

For Technical Support/Warranty Information please call 310-762-9944



Installation Instructions:

(Part # SB76881)

2007-2010 Jeep JK 2Door

XRC Rear Armor Corner Guard Kit

Step 7: Test fit the rear armor fender (93-7267 driver and 93-7277 pass) using C-clamps around the outside of the panels through the windows. Fig B & C.

IMPORTANT!: Align the upper edge of the armor with the body line. The bottom rear edge of the armor should line up with the radius of the lower edge. The front of the armor should be aligned so that it provides proper clearance for door operation. Fig B & C.

Step 8: Once the armor fender is properly aligned and clamped into place, mark the appropriate holes for drilling. Fig B & C.

NOTE: If you are reinstalling the license plate box to the vehicle, place the supplied drill template on the rear of the driver side fender against the tailgate. Using the holes in the template mark the driver side armor fender for drilling.

Step 9: Remove the armor fender and center punch the previously applied marks for drilling. Carefully drill the fender mounting marks out to $\frac{33}{64}$ " and the license plate holes to $\frac{3}{4}$ " and $\frac{3}{8}$ ". Fig B & C.

IMPORTANT!: DO NOT drill through the interior panels.

Step 10: Install the $\frac{3}{8}$ " nutcerts into the previously drilled $\frac{33}{64}$ " holes in the quarter panel.

NOTE: If you do not have a professional nutcert installation tool, use the 2 1/2" X 3/8" socket head bolt, 3/8" nut and washer. Install the nutcert into the 1/2" hole on the vehicle. Thread the nut up as far on the 3/8" bolt as it will go and then follow that with the washer. Thread the bolt, nut, washer, nutcert tool (96-5951) and star washer assembly into the nutcert. (Fig. A) While holding the 3/8" bolt with an Allen wrench, tighten the nut and washer down against the nutcert. Use the nutcert tool and star washer to keep the nutcert body from spinning while tightening the 3/8" bolt. Once the nutcert is properly installed into the vehicle remove the 3/8" bolt, nut, washer, nutcert tool (96-5951) and star washer.

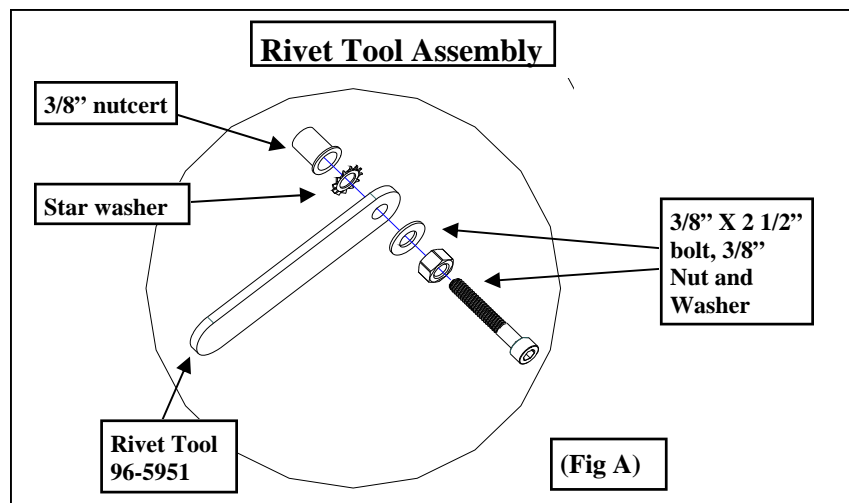

For Technical Support/Warranty Information please call 310-762-9944



Installation Instructions:

(Part # SB76881)
2007-2010 Jeep JK 2Door
XRC Rear Armor Corner Guard Kit

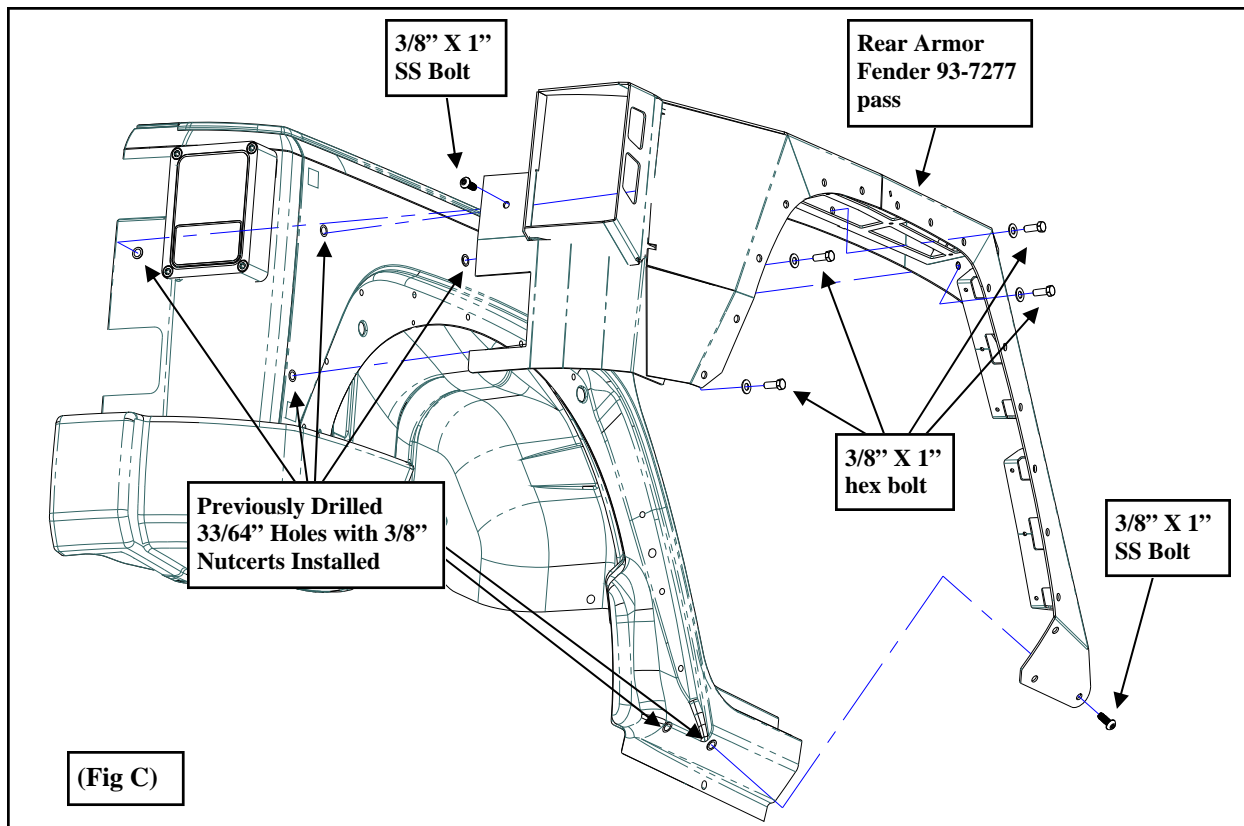
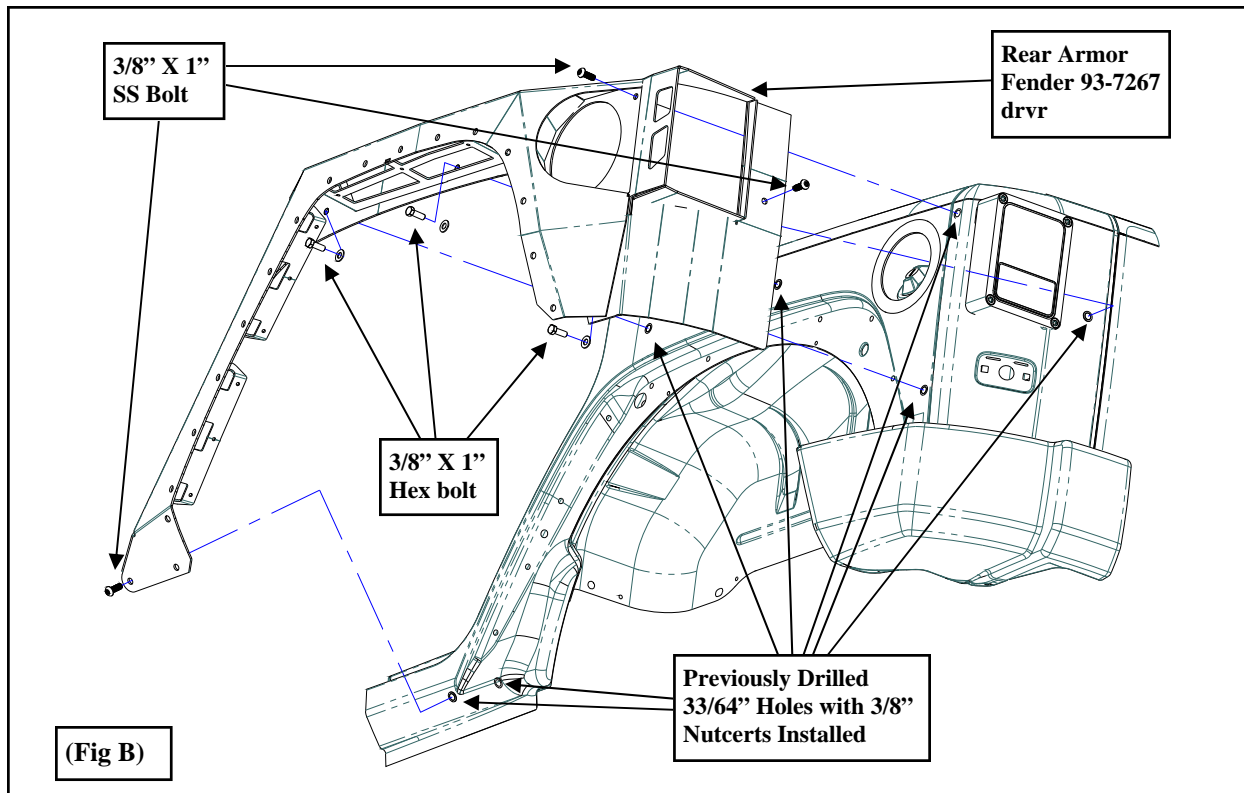

For Technical Support/Warranty Information please call 310-762-9944



Installation Instructions:

(Part # SB76881)

2007-2010 Jeep JK 2Door

XRC Rear Armor Corner Guard Kit

Step 11: Install the supplied fender weather stripping (90-4330) to the upper and front edges of the armor. This will provide a weatherproof seal to the body of the vehicle.

Step 12: Test fit the stainless steel vent backing plates (90-7286 **drvr** and 90-7287 **pass**) into the back side of the armor fender vents. Once the proper fit is verified, install the vents using the supplied double sided tape (90-4345).

Step 13: Reinstall the armor fender (93-7267 **drvr** and 93-7277 **pass**), using the clamps, in it's appropriate position and check the alignment of the nutcerts and the mounting holes in the armor. Slot the holes in the armor if necessary to avoid cross threading the bolts. Fig. B & C.

NOTE: The nutcerts are prone to spinning if not installed properly or cross threaded. Be sure to start the bolts by hand in the nutcerts.

Step 14: Remove the clamps and secure the armor fender using the supplied 3/8" X 1" bolts and hardware. Be sure to start all the bolts by hand to avoid cross threading the bolts. Fig. B, C & E.

NOTE: Be sure to use the Stainless 3/8" X 1" bolts on the exposed mounting holes.

Step 15: Install the fender lip guard (93-7055 **drvr** and 93-7056 **pass**) to the outside of the wheel well using the supplied 3/8" X 1" stainless button head bolts. Fig. D.

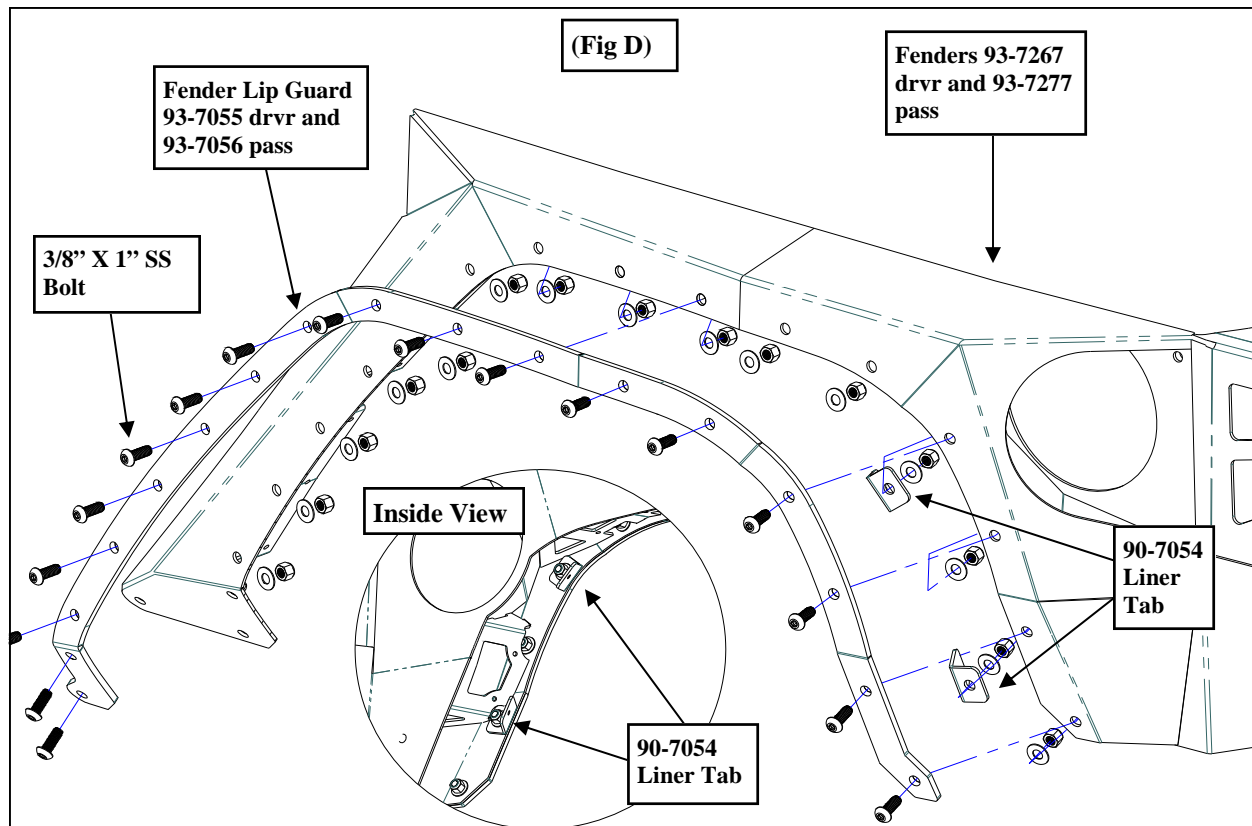

For Technical Support/Warranty Information please call 310-762-9944



Installation Instructions:

(Part # SB76881)

2007-2010 Jeep JK 2Door XRC Rear Armor Corner Guard Kit

Step 16: Install the inner fender liner tabs (93-7054) to the (2) rear bolts (2nd up from the bottom and the 4th up from the bottom). Fig. D.

Step 17: Install the inner fender liner (93-4324 *drv*r and 93-4325 *pass*) into the armor using the supplied plastic retainers. Start in the middle and work your way to the outside edge. Fig. E.

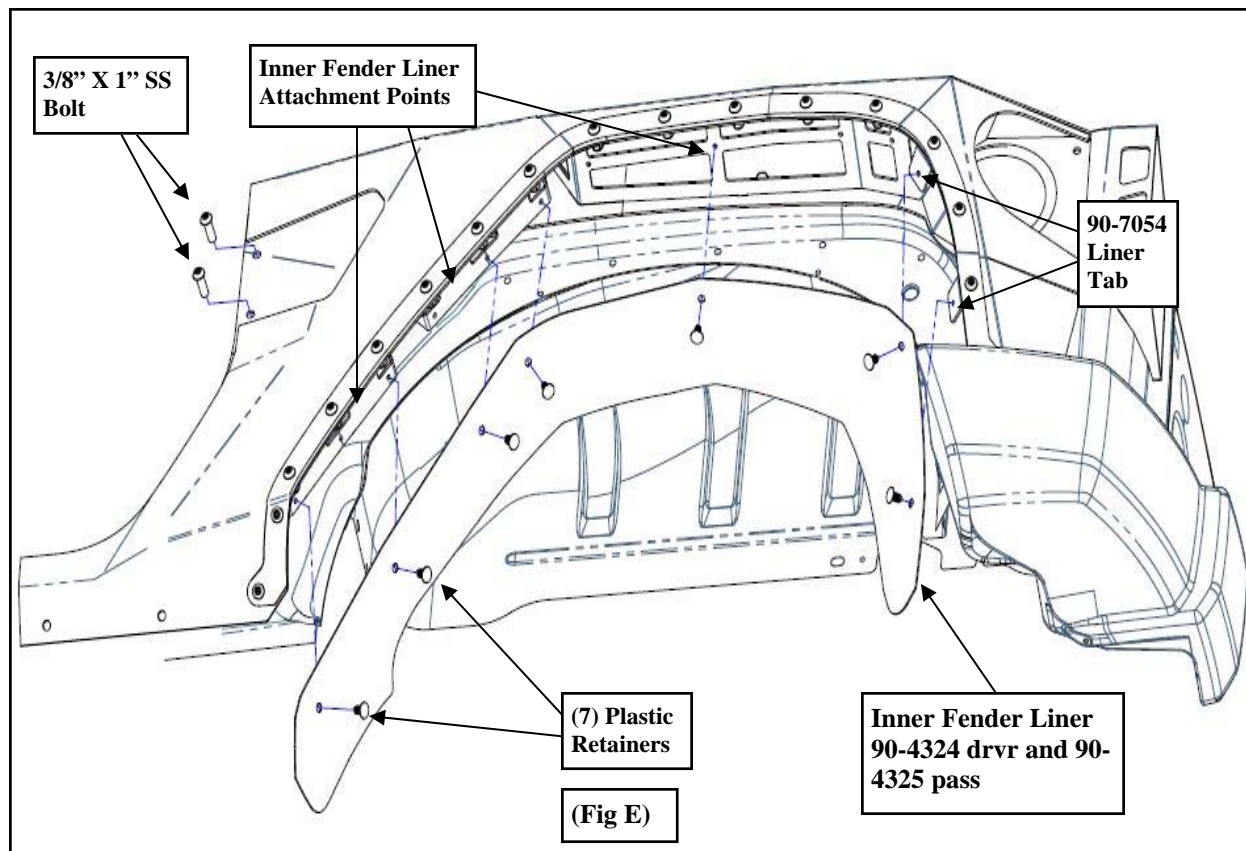

Step 18: Reinstall the **OE** tail lights to the tail light bezels on the armor fenders using the previously removed **OE** hardware.

Step 19: Repeat the previous steps on the remaining side of the vehicle.

Step 20: Reinstall the previously removed rear bumper using the previously removed hardware. Torque according to manufacturers specifications.

Step 21: If you are reinstalling the license plate, route the wiring harness through the armor fender and reconnect the light wiring clip. Install the license plate box to the armor fender using the previously removed **OE** hardware.

For Technical Support/Warranty Information please call 310-762-9944



Installation Instructions:

(Part # SB76881)

2007-2010 Jeep JK 2Door

XRC Rear Armor Corner Guard Kit

Step 22: Reinstall the steps and/or sliders from the vehicle using the previously removed OE hardware.

Step 23: Torque all OE hardware according to manufacturers specifications or the supplied hardware according to the torque chart below. Installation is now complete.

Bolt Torque and ID						
Decimal System			Metric System			
All Torques in Ft. Lbs.						
Bolt Size	Grade 5	Grade 8	Bolt Size	Class 9.8	Class 10.9	Class 12.9
5/16	15	20	M6	5	9	12
3/8	30	45	M8	18	23	27
7/16	45	60	M10	32	45	50
1/2	65	90	M12	55	75	90
9/16	95	130	M14	85	120	145
5/8	135	175	M16	130	165	210
3/4	185	280	M18	170	240	290

<p>1/2-13x1.75 HHCS</p> <p>Grade 5 Grade 8 (No. of Marks + 2)</p> <p>D T L X</p>	<p>M12-1.25x50 HHCS</p> <p>D T L X</p>
--	---

G = Grade (Bolt Strength)	P = Property Class (Bolt Strength)
D = Nominal Diameter (Inches)	D = Nominal Diameter (Millimeters)
T = Thread Count (Threads per Inch)	T = Thread Pitch (Thread Width, mm)
L = Length (Inches)	L = Length (Millimeters)
X = Description (Hex Head Cap Screw)	X = Description (Hex Head Cap Screw)

For Technical Support/Warranty Information please call 310-762-9944



Installation Instructions:

(Part # SB76881)

2007-2010 Jeep JK 2Door

XRC Rear Armor Corner Guard Kit

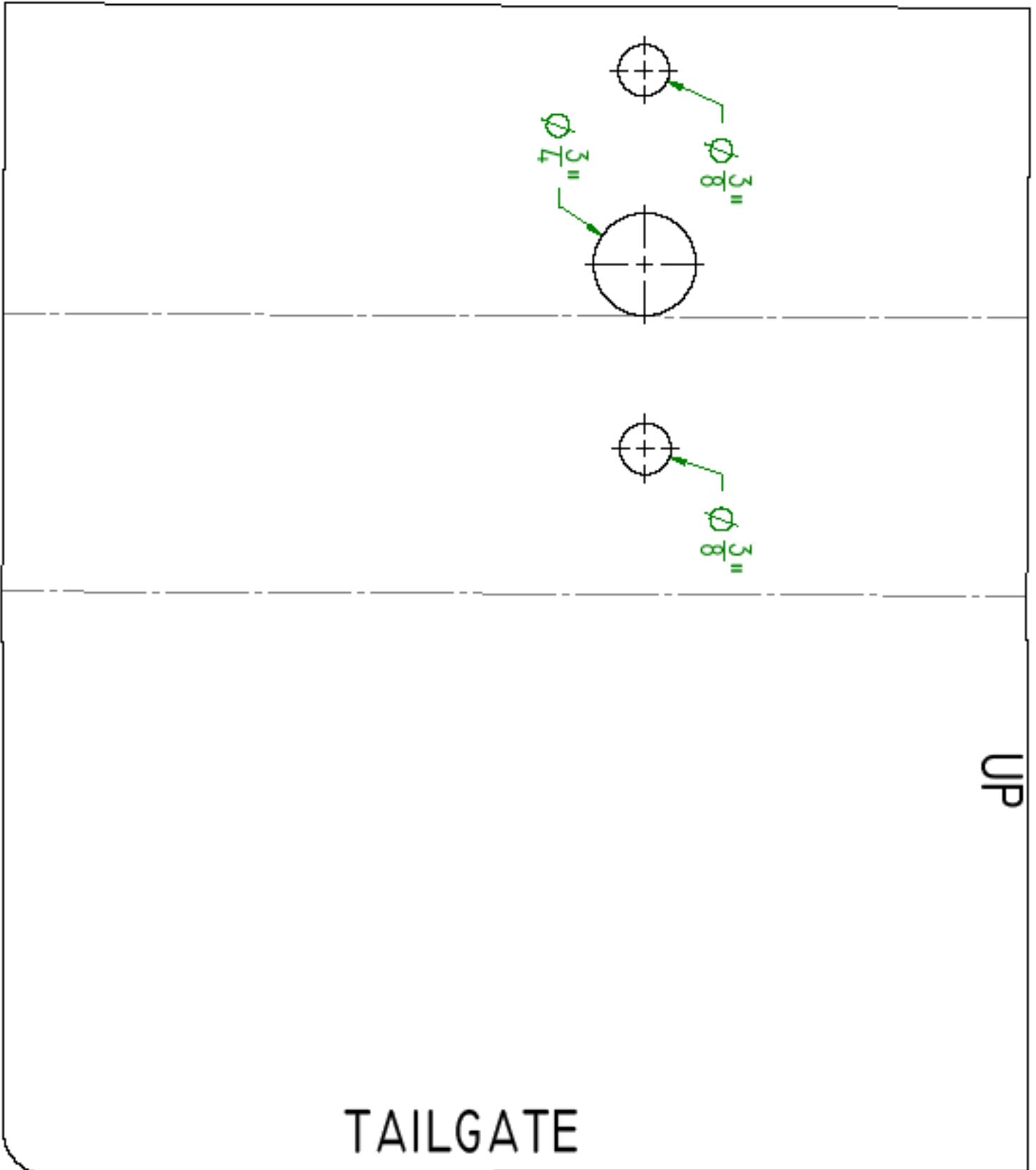



Installation Instructions:

(Part # SB76881)
2007-2010 Jeep JK 2Door
XRC Rear Armor Corner Guard Kit

Limited Warranties

Smittybilt's products are covered under the following limited warranties only. Note that the duration of the limited warranty differs according to the material and finish of the product purchased. Subject to the duration and conditions of the limited warranty stated below, Smittybilt warrants to the original retail purchaser that its products are free from defects in material and workmanship. All other warranties and representations express or implied, are hereby disclaimed, including fitness for merchantability and buyer's intended use or purpose. All parts are sold "AS IS" except for the limited warranties granted herein. Buyer assumes all risks as to the selection, suitability and performance of all goods and products selected. This limited warranty does not cover damage or impairment in any part due to misuse, improper installation, accident or contact with on-road or off-road hazards, product modification, improper or inadequate cleaning and/or maintenance. Smittybilt is not responsible for items damaged during shipping. This warranty is not transferable from the original buyer. For the original Buyer to be eligible for the limited warranty coverage, the Buyer must provide proof of purchase. Smittybilt strongly recommends returning the warranty registration card.

Customer's remedy hereunder shall be limited only to repair or replacement (at Smittybilt's option) of any defective part(s) returned to Smittybilt at customer's expense. The determination of whether or not a returned part is defective or subject to coverage under the limited warranties stated herein shall be made at Smittybilt's sole discretion.

Duration of Limited Warranty

Limited Lifetime Warranty on Stainless Steel Products -

Smittybilt stainless steel products carry the foregoing limited repair or replacement warranty against workmanship and defects in the material so long as the original purchaser retains the original stainless steel parts.

Limited Five (5) Year / 50,000 Mile Pro-Rata Warranty (whichever occurs first) on Dual-Stage Powder Coating Products -

Smittybilt dual-stage powder coated products carry the foregoing limited repair or replacement warranty for a period of (5) years or 50,000 miles (whichever occurs first) from date of purchase against workmanship and defects in the material, provided that any claim submitted after (2.5) years from date of purchase shall, if accepted, be satisfied by Smittybilt offering customer a credit on the purchase of a replacement product equal to fifty percent (50%) of customer's initial purchase price.

Limited Three (3) Year / 36,000 Mile Pro-Rata Warranty (whichever occurs first) on Chrome Products-

Smittybilt chrome products finished carry the foregoing limited repair or replacement warranty for a period of three (3) years or 36,000 miles against workmanship and defects in the material (whichever occurs first) from the date of purchase.

For Technical Support/Warranty Information please call 310-762-9944